

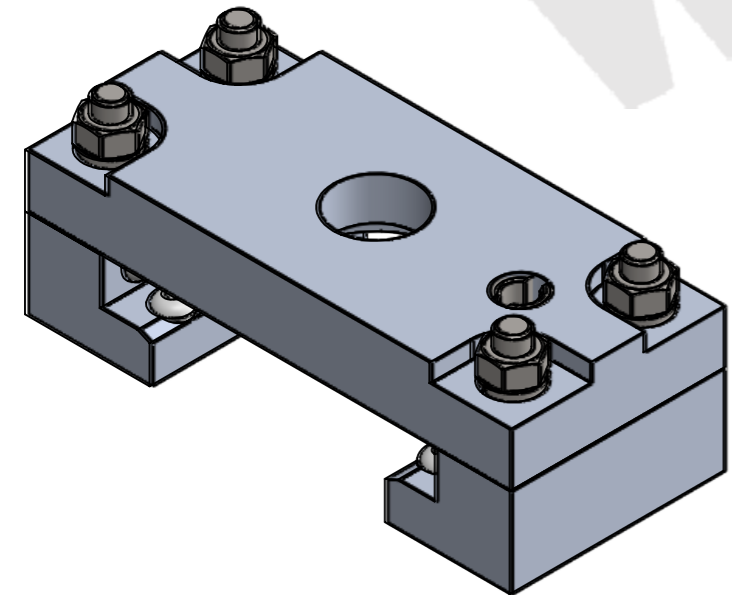

COUPE D-D
ECHELLE 1 : 1.5

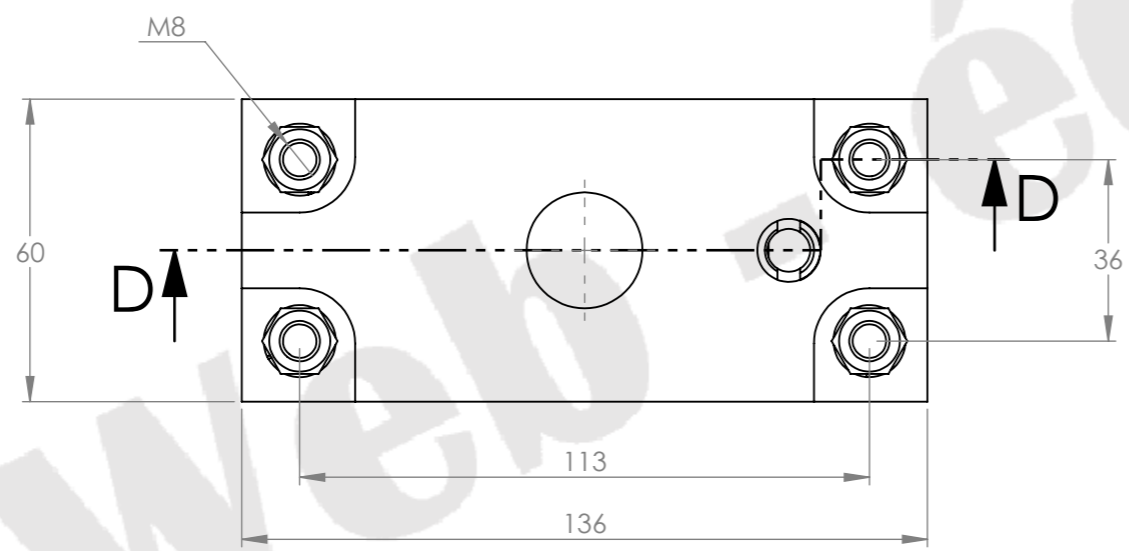
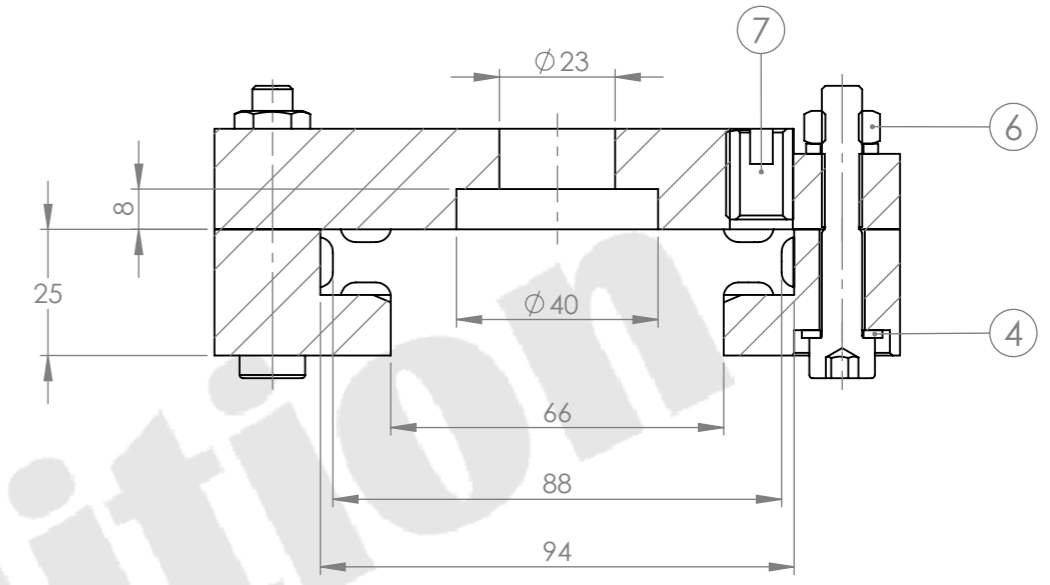
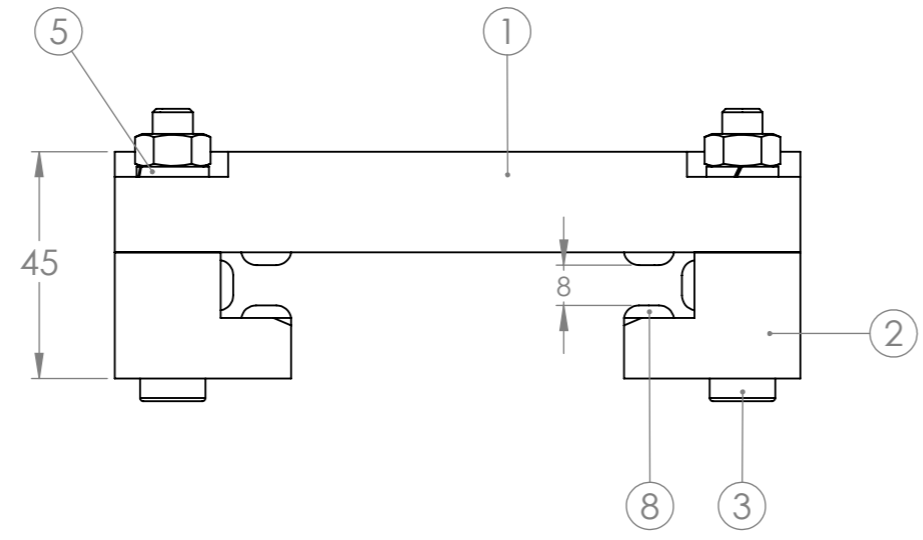

No. Article	Désignation	Matière	Qté.
1	Corps de pince glissante	EN AW 6060	1
2	Bride de serrage	EN AW 6060	2
3	Vis M8x50 - ISO 4762	Inox A2-70	4
4	Rondelle M8 - ISO 7092	Inox A2	4
5	Rondelle grower M8 - ISO 1751	Inox A2-70	4
6	Écrou M8 - ISO 4032	Inox A2-70	4
7	Insert M10	Inox	1
8	Pion de glissement	Acetal homopolymère	12

Révision	Commentaire	 MALICO - LAC		
A	Première diffusion			
Dessiné par	T.D	Désignation: Bride de suspension glissante		
Vérifié par	S.O.L	FORMAT A3	No. plan: OCS-0671	Date : 05/11/25
Approuvé par	J.A	Echelle: 1/1,5		Poids: 0,6 kg Feuille: 1/1