

DÉTAIL A
ECHELLE 1 : 1.5

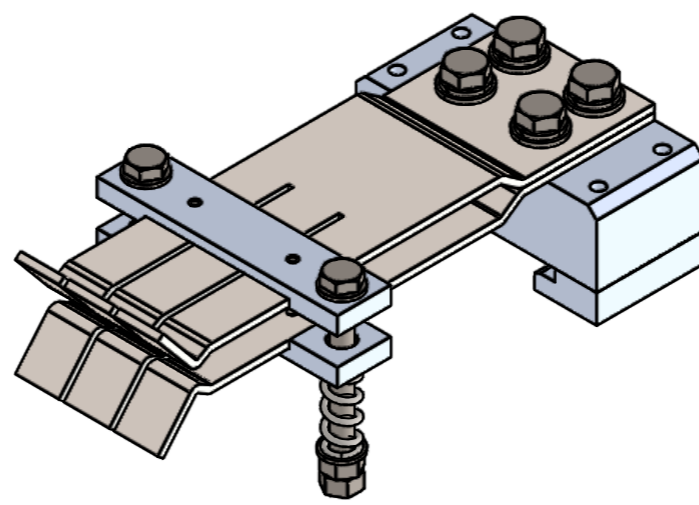
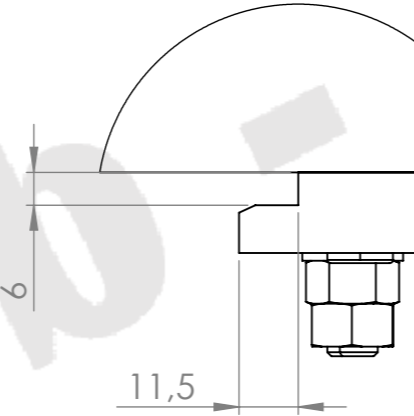

No. Article	Désignation	Matière	Qté.
1	Corps de pince	EN AW 6060 T6*	1
2	Bride de serrage	EN AW 6060 T6*	2
3	Plaquettes	EN AW 6060 T6*	2
4	Contact à ressort	Cu-ETP**	2
5	Ressort	Acier pour ressort	2
6	Goupille mécanindus Ø5x8	INOX A2	4
7	Vis M12x35 ISO 4017	INOX A2-70	4
8	Rondelle M12 ISO 7089	INOX A2	4
9	Vis M8x30 ISO 4762	INOX A2-70	4
10	Rondelle M8 ISO 7089	INOX A2	4
11	Vis M10x100 ISO 4017	INOX A2-70	2
12	Écrou M10 ISO 4034	INOX A2	4
13	Rondelle M10 ISO 7089	INOX A2	6
14	Rondelle grower B12 UNI 1751	INOX A2	4

*Alternativement EN AW 6082 T6

**Traitement d'argenture électrolytique ISO 4521 5-6 µm

Révision:	Commentaire:	
A	Première diffusion	
Dessiné par:	TD	Désignation : Mâchoire d'alimentation
Vérifié par:	SOL	
Approuvé par:	JA	No. plan : OCS-0666
		Date: 23/02/26
		REV: A
		Échelle: 1/2,5
		Poids: 3,3 kg ± 5%
		Feuille: 1/1